

Instruction manual



Thank you for purchasing an in-line refractometer. This instruction manual is designed to guide you to understand the functions and characteristics of the sensor. Before using the instrument, please read this manual carefully to ensure safe and correct use. Please keep this manual for future reference

In-line Refractometer

Model : GND15



Description

The In-line Brix-Monitor GND15 is a refractometer that detects the Refractive Index of a sample and outputs the Brix(%) value on the display , can also transmit measured data to external devices via 4 to 20mA or RS485 . GND15 series has the function of automatic temperature compensation according to the temperature of the tested medium , when the tested medium temperature changes , the Brix value (soluble solids) after temperature compensation is displays and the output changes accordingly

Working Principle

If the Refractive Index of air under atmospheric pressure is 1, then when light enters medium χ , the ratio of the sine of the incident angle α measured against the phase boundary to the sine of the refracting angle β is called the Refractive Index of the medium χ .

The Refractive Index varies with the wavelength of light and temperature and is represented as follows:

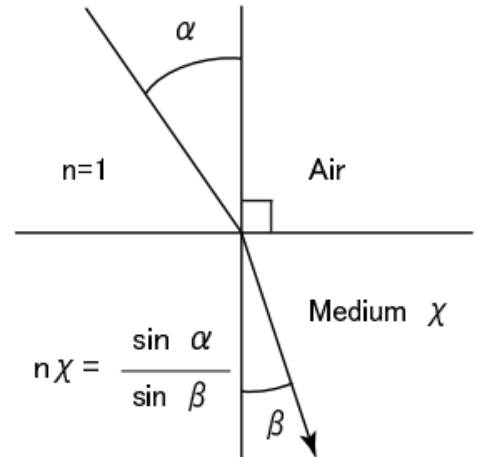

- n : Represents the Refractive Index
- t : Temperature (°C)
- D : D-line of natrium (589nm)

For example: Refractive Index of water at 20°C under the D-line is: $n_D^{20} = 1.33299$; (Generally expressed as $n_D = 1.33299$.)

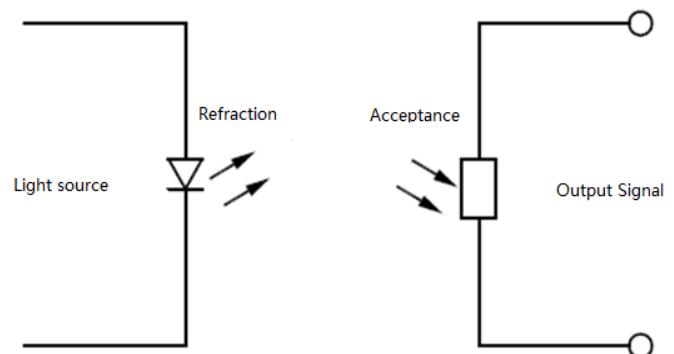
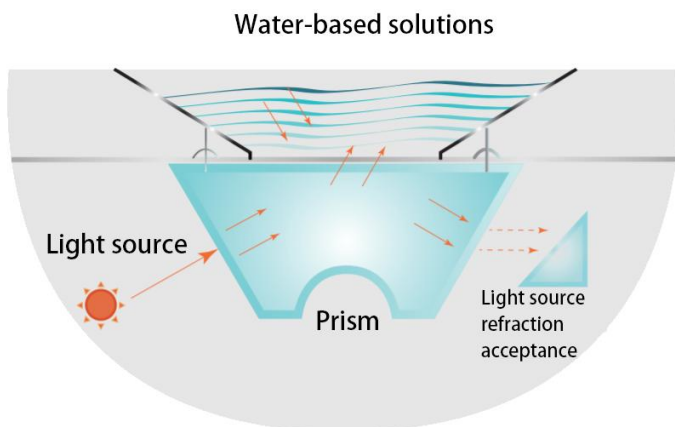

Temperature correction & compensation

The Refractive Index of a substance varies with temperature. Thus, when using a refractometer to measure the Refractive Index of a liquid, the measurement value will vary with the sample temperature. The GND15 always detects the prism temperature. The value of the measurement is automatically corrected for temperature by a built-in processor, so that the displayed value is equal to the value measured at 20°C (provided that the sample temperature is within the range of 5 to 85°C), the Brix(%) values are automatically temperature compensated .

In-line Refractometer

Model : GND15



Features

Automatic temperature compensation

Lightweight , compact and easy to install on site .

LED display ,

Easy to operate, easy to connect with other devices for automatic control

Inline real-time monitoring and control of liquid substance concentration in various industries

Applications

Cutting oil , mold release agent , quenching liquid , cleaning liquid , emulsion in the machining industry

Chemicals and allied , pulp & paper , tobacco , environmental protection

Biorefining , Metals and mining

Food industry , Dairy , Beverage industry , Fruit and effect processing

Starch sweetener , Sugar and sweeteners

Water-based solutions

Why need to install in-line refractometer ?

In factories that produce liquid products such as beverages, medicines, chemicals, etc., the raw materials (stock solution) must be processed in multiple processes, or two or more mixed solutions must be added through multiple production lines and multiple processes, such as: juicing, filtering , cooking, dilution, blending, mixing, fermentation, etc., each process, the concentration will change. If only detect the finished product concentration, when there is a substandard product, it is impossible to know which process has the problem, and the produced defective product causes cost waste. Therefore, an online refractometer is installed on the production line (production pipeline, tank) of each process. , It can continuously detect the concentration of samples in the pipeline in real time, monitor the quality of samples in each process, and discover unqualified products in time, which can reduce production costs, improve the pass rate and product quality. cost, improve inspection efficiency, real-time display of brix value , and intuitively guide production personnel to operate.

In-line Refractometer

Model : GND15



Specification

Model:	GND15
Measure Parameters:	Refractive index(nD), Brix (%), Temperature (° C)
Measure range:	0-15% , 0-33% , 0-53% , 93%
Min Resolution Ratio:	Brix: 0.1% (Range for 15% , 33% & 53%) Brix: 0.5% (Range for 93%)
Measurement Accuracy:	Brix:±0.1%, Brix:±0.3% (standard)
Measurement Temperature:	0-85°C(Automatic Temperature Compensation)
Operating current:	≤200mA
Display menu:	Refractive index(nD) , Brix(%), Temperature (° C)
Output :	4-20mA , 4-20mA+ RS485 optional
Power:	12-24V DC
Wetted parts material:	Prism: sapphire, Prism stage: SS304 , SS316L (can be customized)
Optical source:	LED(the wave length approximate to D line)
Max Pressure:	1MPa
Environment Temperature:	0-40°C
Protection grade:	IP67
Instrument Size:	175mm*120mm*120mm
Process connection	3" tri-clamp , other size supply free adaptor
High and low limit settings	Buttons can be set
Recorder output cable	2M ,3M ,5M,10M optional
Temperature sensor	Thin film platinum sensor

In-line Refractometer

Model : GND15



Dimension

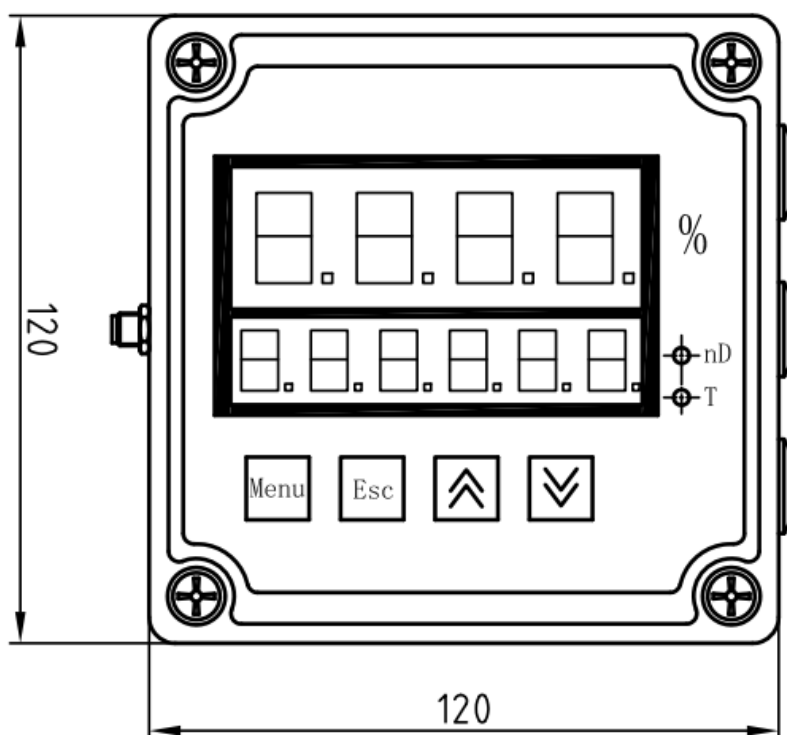
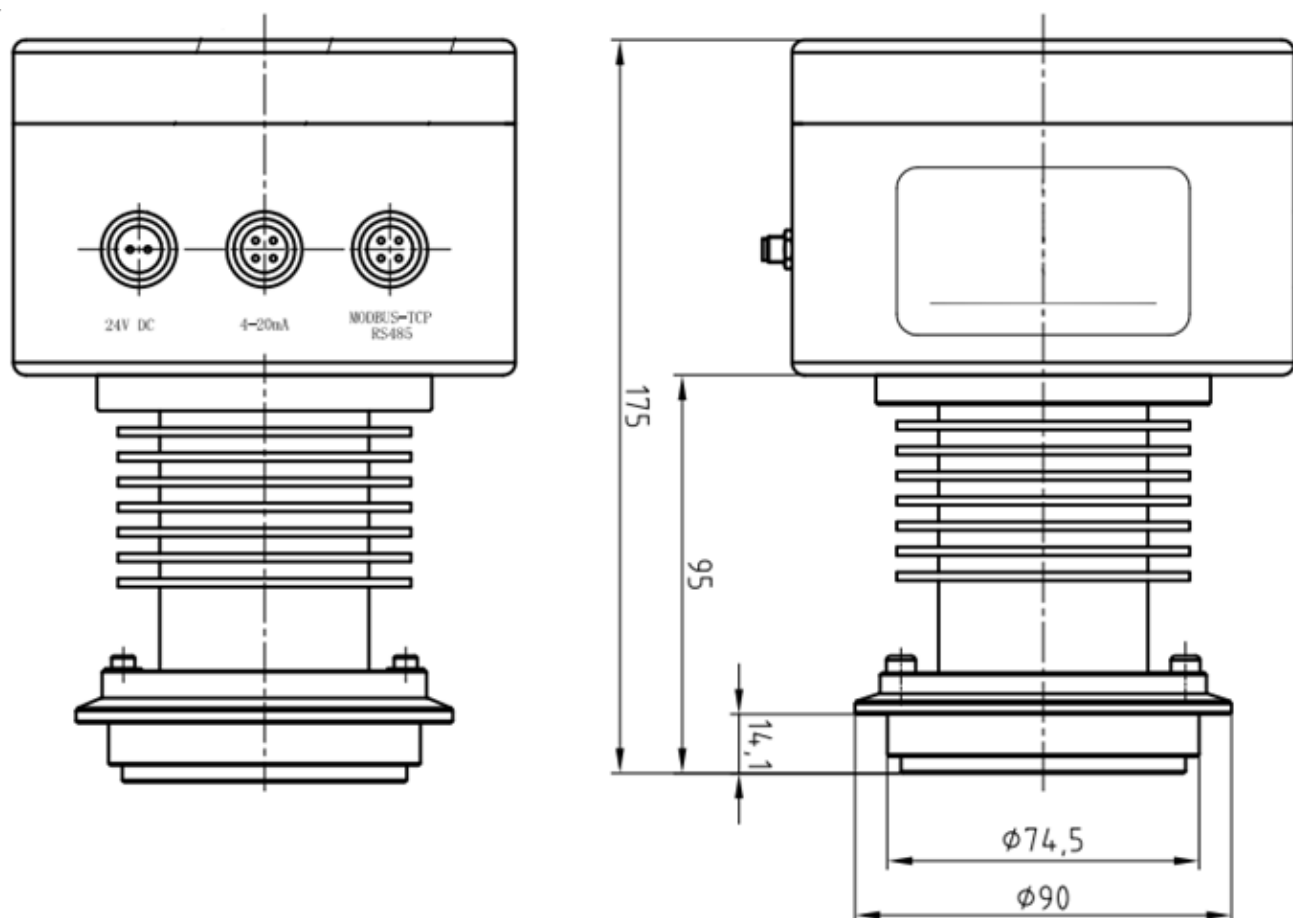

In-line Refractometer

Model : GND15



Names and Functions of Components

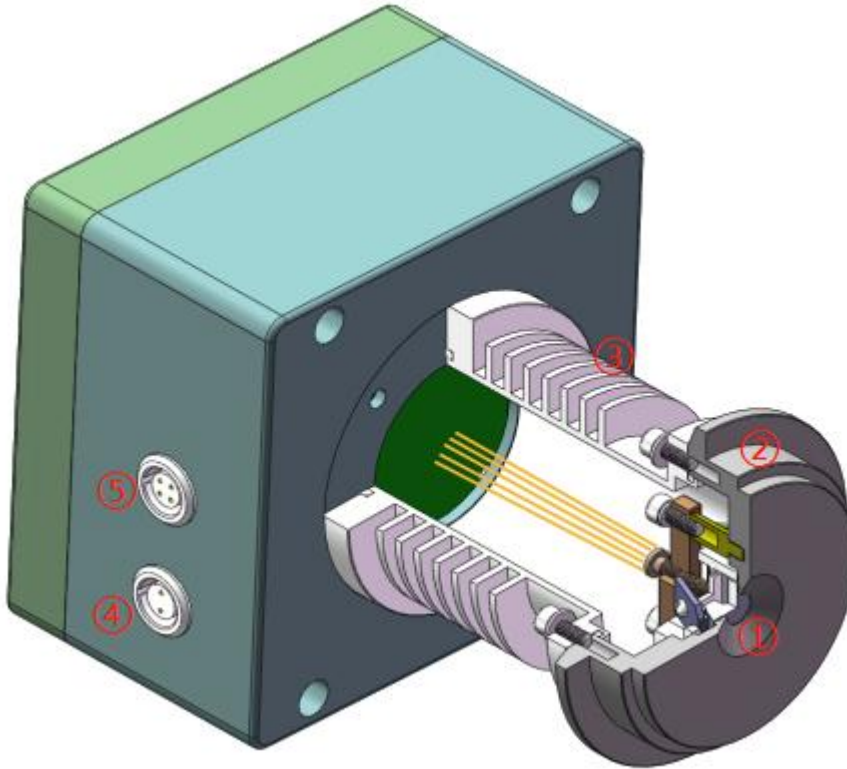

①Prism : Corrosion resistant optical glass, with a polished surface to reflect light.

② Prism stage :Connected to the sample inlet and fastened by a O-Ring and clamp band .

③Radiator: Disperses heat when measuring high temperature samples to prevent the electric circuit from overheating.

④2-pins plug for unit power (24VDC)

⑤4-pins plug for output (4-20mA or 4-20mA + RS485) , connect to a recorder.

Note: our GND15 as no power switch. Turn off the power (DC24V) prior to connecting cables to the individual units. When power is supplied to the GND15 , The Brix(%) value will be displayed when sample flows onto the prism surface, the measurement value display illuminates , the unit work commences. If there is no sample on the prism surface (only air), the error message [LLLL] will be displayed.

In-line Refractometer

Model : GND15



Names and Functions of keys



- ① Measurement brix value display : Digitally displays the measurement value [Brix(%)], setting mode, and other setting values.
- ② Measurement value display : Digital switch displays the measure value [nD and T]
- ③ Menu: Switches or sets the display mode of the measurement value and the setting mode, and save the setting value .
- ④ESC: Exit key
- ⑤ \wedge : Up keys : Increase the value in each setting mode.
- ⑥ \vee : Down key: decrease the value in each setting mode .

In-line Refractometer

Model : GND15



Button definition and operation

In the measurement interface, press Menu to enter the first level menu, and ESC to return to the measurement interface. Under the first level menu, you can use the up and down keys to select the corresponding options. When you press Menu, you will enter the second level menu. The up and down keys will adjust the corresponding options. After adjustment, press Menu to save the settings and return to the first level menu. After adjustment, press ESC to not save and Return to the first level menu.

	First level menu	Second level menu
1	Measurement interval	4,6,8,10 S
2	Calibrate 0	Calibration 0 returns to the main page successfully, EE0 is displayed if it fails
3	Brix corresponding to the upper limit of 20mA in the current 4~20mA	Default value depend on the measurement range
4	Decimal places	0 , 1 , 2
5	Display temperature, refractive index or polling display	1=temperature, 2=refractive index, 3=polling display
6	Mode-S measurement stability	1, 2, 3, 4, 5 total 5 gears
7	Temperature correction in units of 0.1	Increase or decrease by 0.1
8	Brix corresponding to the lower limit 4mA in the current 4-20mA	Default 0%
9	Temperature 4-20mA upper limit 1 as the unit (Reserved functions)	Increase or decrease the upper limit of the solution 4-20mA output by 1. When the temperature value is greater than or equal to the upper limit, the output is 20mA, and the value range is -10-130
10	Temperature 4-20mA lower limit 1 as the unit (Reserved functions)	Increment or decrement the lower limit of the 4-20mA output of the solution by 1, when the temperature value \geq the upper limit, the output 4mA, the value range is -10-130
11	The alarm high limit is 1 as the unit	When the measured concentration exceeds the high limit, the display flashes quickly, and the value range is 0-100 When the setting value is greater than 95, it is equivalent to turning off the alarm output
12	Alarm low limit 1 as unit	Increase or decrease by 1 when the measured concentration is lower than the low limit, display Slow flashing, when the set value is less than 0, it is equivalent to turning off the alarm output
13	Device ID address	Default is 1
14	Reset	Return to the main page after successful reset, display EE1 on failure

In-line Refractometer

Model : GND15



Operation instructions

- Step ① : Wipe the prism surface clean before starting the measurement
- Step ② : Connect the power to GND15 the measurement starts .
- Step ③ : Calibrate 0 with distilled water (The factory Settings of the product have been validated)
- Step ④ : Install well our GND15 on the location that needs to be measure .
- Step ⑤ : When the sample flows into the prism surface
- Step ⑥: measurement starts , brix (%) value and current temperature T will be displayed .

Screen display code definition

Boot displayNo solution display

【-----】
【-----】

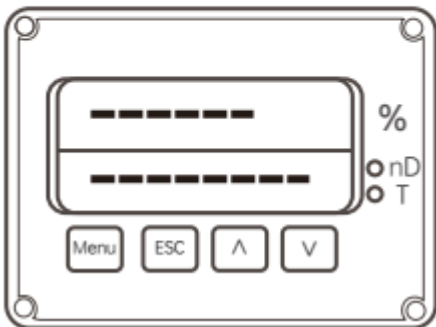

Brix exceeds the measuring range ay

LLLL
T (Current Temperature)

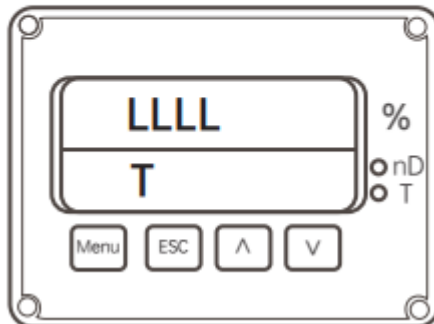

HHHH
T (Current temperature)

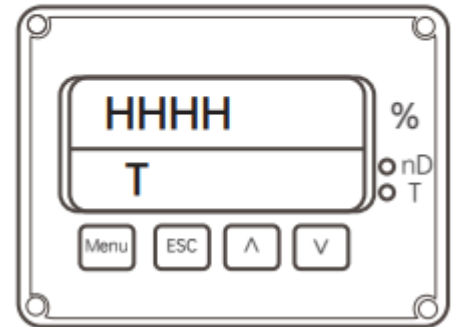

Normal measurement display

*** (Current Brix)
T (Current Temperature)

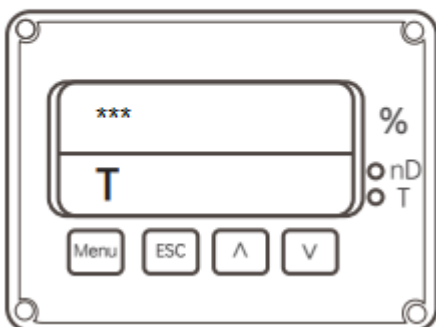

nD & T polling displayCalibration 0 failure display EE0

or nD or both through the menu.

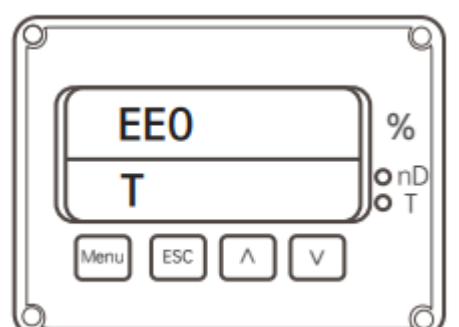
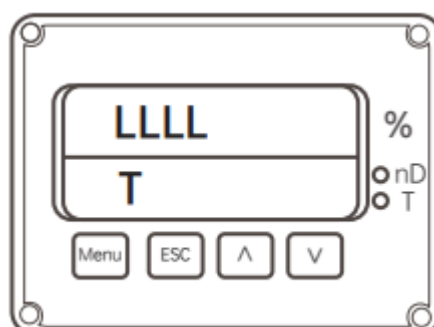

In-line Refractometer

Model : GND15



Mounting Precautions

- ◆ The installation form of this product is a hoop quick-installation type;
- ◆ When installing, please pay special attention not to scratch the prism and probe;
- ◆ When installing, please pay special attention to avoid strong impact on the instrument;
- ◆ When installing, please pay special attention not to miss the sealing ring;
- ◆ Ensure that the cable is correctly connected to the port;
- ◆ The power can be turned on only after the product is installed;
- ◆ Immediately turn off the power (DC24V) if the unit begins to overheat, smoke or emit an abnormal smell.

Mounting type 1: Compact small pipe installation

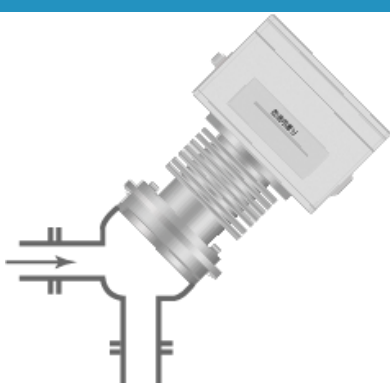

Small curve pipe

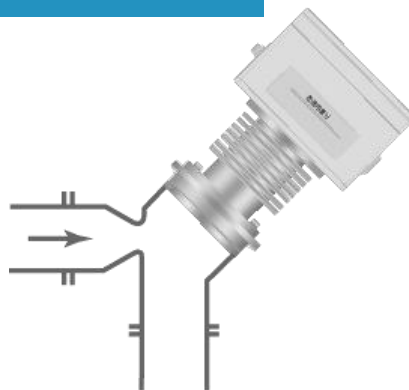

Neck to increase flow rate pipe

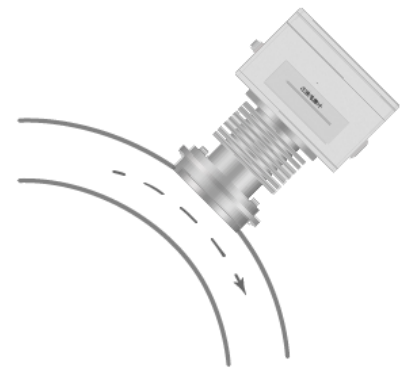

Normal curve pipe

Mounting type 2: Large pipeline and container installation

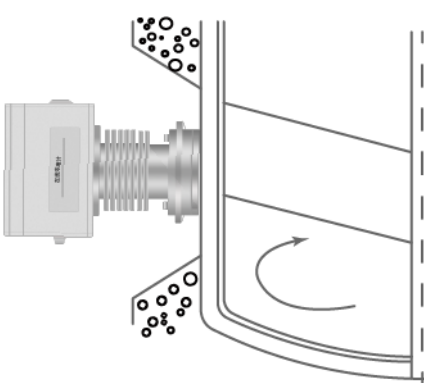

Digester with scraper and steam

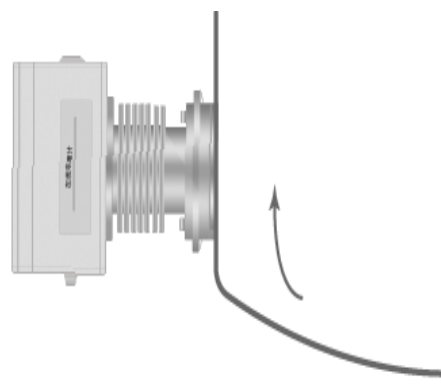

Container

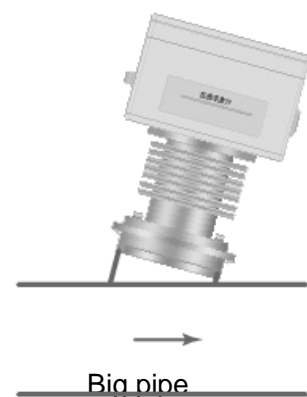

Big pipe

In-line Refractometer

Model : GND15



Mounting procedure:

- ① Install the GND15 so that the prism surface is at a right angle to the ground.
- ② Attach the flow pipe to the GND15 with O-ring (accessory) inserted between them, and fasten them together with the clamp band (accessory).
- ③ The prism surface may become contaminated with solids, dirt and/or grease. If this happens, the prism surface must be cleaned by hand.

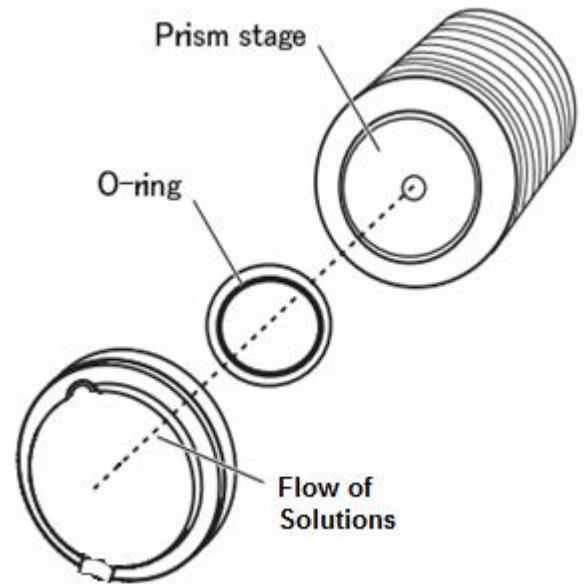

Note : Cleaning the Prism instruction in the next page
The sample inlet unit should be installed in such a manner that it can be easily removed to allow access to the prism for cleaning

Note : Suspending the GND15 (2.5kg) when using the sample inlet unit to connect to the piping is dangerous , Use of the optional stand is recommended.

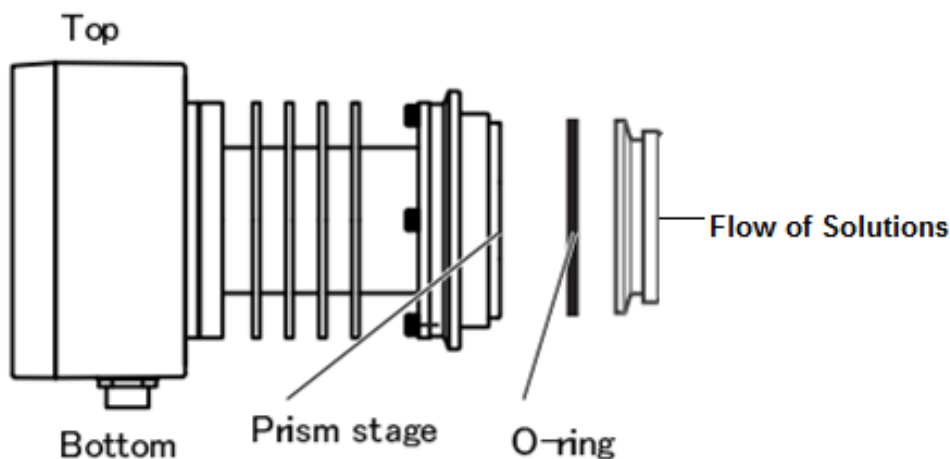
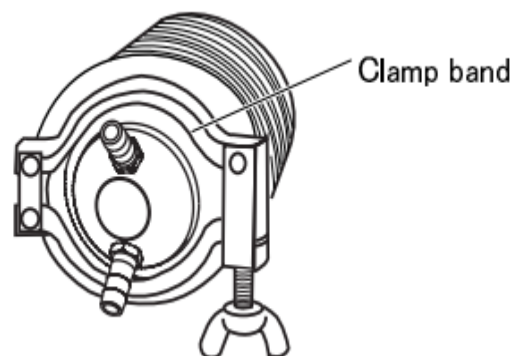

In-line Refractometer

Model : GND15



Cleaning the Prism

- ◆ If the sample solution could potentially stain the prism, immediately clean the prism after measurement .
- ◆ Before running hazardous substance(s) through any precautions should be taken to ensure the safe handling of the hazardous system, necessary substance(s). If using a sample inlet unit, use caution when disconnecting the GND15 .
- ◆ Cleaning liquids up to 150°C can be used for CIP or SIP . The cleaning liquid can be used safely for 30 minutes at one time. The momentary difference between the sample liquid temperature and the cleaning liquid temperature must be no more than 80°C. When using cleaning liquids at temperatures over 150°C, the power source (DC24V) must be turned off.
- ◆ Detach the clamp band that connects the main unit to the sample inlet unit, piping or tank.
- ◆ Clean the prism surface carefully with a soft tissue soaked with warm water or ethyl alcohol. If the sample solution contains oil or grease, use ethyl alcohol to ensure the prism surface does not develop a film. Development of a film on the prism could cause erroneous measurements.
- ◆ NEVER clean the prism with an abrasive material.
- ◆ Cleaning the prism with an abrasive material could cause scratches on the prism which could lead to erroneous measurements.
- ◆ After cleaning is complete, re-attach the GND15 unit to the sample inlet unit, piping or tank. The procedure is described on the instruction manual.

Note :we also can supply Auto or manual washing device for optional, if need , Please specify when confirming the order

In-line Refractometer

Model : GND15



Environmental conditions:

- ◆ If the unit begins to overheat, smoke, or emit an abnormal smell , immediately turn off the power and unplug the unit from the power supply.
- ◆ DO NOT measure any sample that can damage the prism or the sample inlet unit , sample temperature should be kept between 5°C and 100°C when the power is turned on .
- ◆ Do not put the instrument in a damp place, Maximum average relative humidity: 95% RH (25°C);
- ◆ Atmospheric pressure: 80kPa ~ 106kPa;
- ◆ Places where there is no corrosion or destruction of insulating gas, steam or dust;
- ◆ Use the instrument at altitudes below 2000 meters (altitude).
- ◆ Use the instrument indoor.
- ◆ Do not change the ambient temperature of the instrument suddenly
- ◆ Do not use instrument in areas with large amount dust and strong vibrations
- ◆ Do not put the instrument in low temperature place
- ◆ Do not put heavy objects on the instrument
- ◆ Do not install the instrument In direct sunlight or near the heating source.

Breakdowns And Trouble Shooting :

If measurement of concentration transmitter is abnormal, please check input power supply first. If power supply is ok, check if the measurement window of transmitter has been covered by contamination or not, and make sure that measurement window can contact solution well at the mean time. If it is problem of transmitter itself, please return it to the factory for maintenance.

Caution :

- ◆ Protected from direct rain and snow, the packaged transmitter can be applied to various modes of transportation, such as water, land and air transportation.
- ◆ The packaged transmitter can be stored for more than 12 months with temperature ranging from -40°C~60°C, and relative humidity less than 90%
- ◆ Live plug-in and pull-out should be strictly prohibited under live working condition, otherwise, it will damage the concentration and infrared transmitter easily.

In-line Refractometer

Model : GND15



Plug wiring definition:

<p>2-pins plug for unit power (24VDC)</p>		<p>Pin1: 24V Power+ (V+): Red Pin 2: 24V Power- (V-): Black</p>
<p>4-pins plug for output (4-20mA) (4-20Ma +RS485)</p>		<p>Pin 1: 4-20mA+ (I+): Red Pin 2: 4-20mA- (I-), Black Pin 3: RS485B, Yellow Pin 4: RS485A, Green</p>

Product and accessories :

1 Main unit



2 Calibration sheet



3 Two-pins plug mating cable



4 Four-pins plug mating cable



5 O-Ring



6 Clamp band



7 Pass certification



Ordering guide :

with * are required, with --- is optional

Model	Range (%)	Output	Process connection	Electric connection	Accuracy	Other requirement
GND15	*	*	*	*	*	---
Example: GND15-33%-4-20mA-3" tri-clamp- 4pins -0.5%						

Shanghai Zhaohui Pressure Apparatus Co., Ltd.

5-6F No.8 Building No.115 ,Lane 1276 Nanle Road Songjiang District Shanghai 201600 China
 Tel:+86-21-51691919 67755189 Fax:+86-21-67755185
 E-mail: info@zhyqsensor.com
 www.zhyqsensor.com